

RAS 98 ULTRA TW

with double-system expanding hub and rim assembly

MACHINE SUITABLE FOR TRUCK TYRES
UP TO 445/65 R 22.5" AND 495/45 R 22.5"



- 15" COLOUR TOUCH SCREEN USER INTERFACE. The industrial PC features two USB ports for data backup and software updating.
- COMPREHENSIVE SELF DIAGNOSTIC AND TROUBLESHOOTING SYSTEM.
- ARTICULATED BUFFING/BRUSHING ARM, COMPUTERISED SIDEWALL BRUSHING UNIT and CABLE LIFT are available on request.

- THE MACHINE CAN PROVIDE ANY BUFFED PROFILE. Each buffing programme can control up to 3 different buffing radii and relevant speeds for the crown area (negative radius is also possible) and 3 radii for the sidewalls.

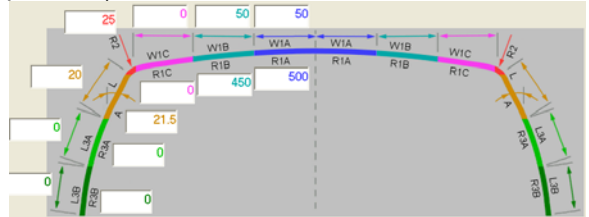

- "BEC 90" STEEL BELT DETECTOR AND "LASER 300" COMPUTER INTERACTIVE CIRCUMFERENCE MEASURING DEVICE. "BEC 90", used in combination with "LASER 300", allows different operating options that include tyre casing buffing with diameter/circumference set to zero so that buffing profile is completed according to rubber thickness to be left on the steel belts.



MACCHINE PER PNEUMATICI E PER I PROCESSI DI RICOSTRUZIONE
EQUIPMENT FOR THE TYRE AND RETREADING INDUSTRIES

matteuzzi srl

Via Serra, 1/E - 3
40012 CALDERARA DI RENO, ITALY
Phone ++39 - 051726351

matteuzzi@matteuzzi-srl.com - www.matteuzzi-srl.com

RAS 98 ULTRA TW

with double-system expanding hub and rim assembly

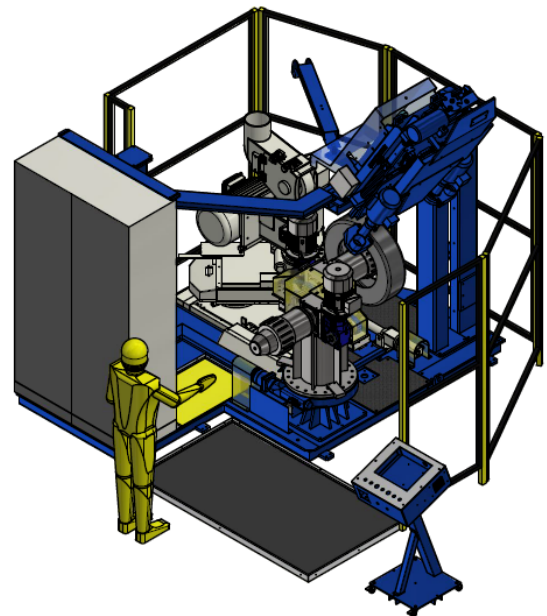
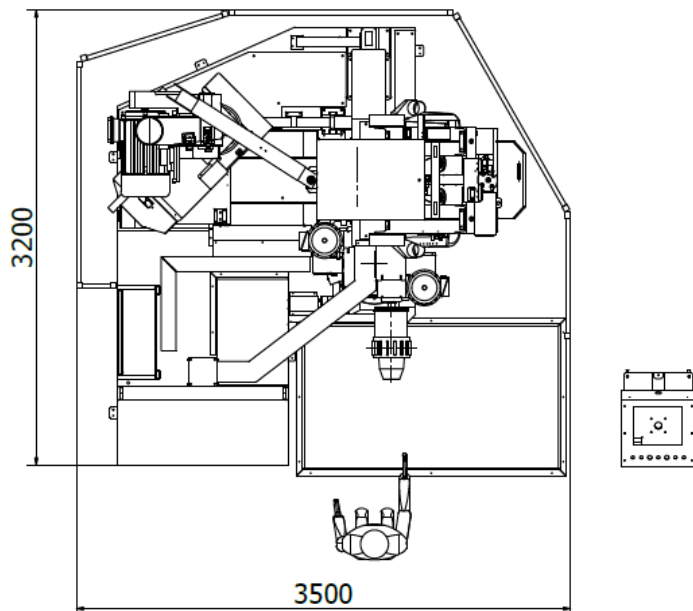
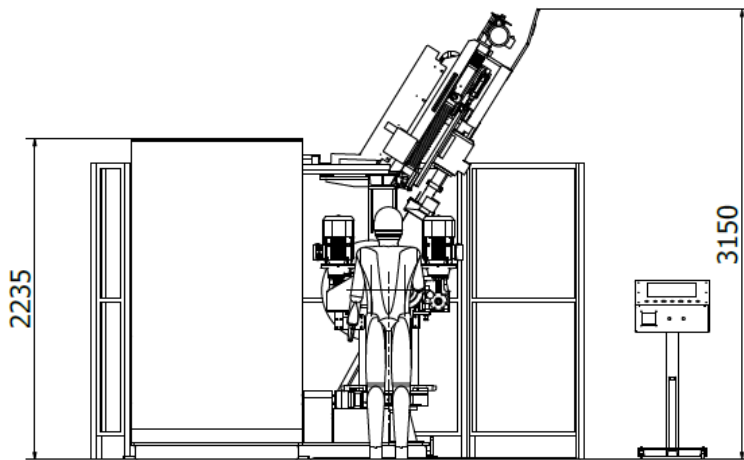

dimensions of the machine in service

tyre size range	14" - 24.5" (including 445/65 R 22.5" and 495/45 R 22.5")
total installed power	52 kW (70 HP) includes 40 HP rasp head motor
compressed air supply	8-10 bar (120-150 PSI)
compressed air absorption	600 NI (21 cu ft) per cycle/approx.
net weight	2900 kg (6393 lbs)



MACCHINE PER PNEUMATICI E PER I PROCESSI DI RICOSTRUZIONE
EQUIPMENT FOR THE TYRE AND RETREADING INDUSTRIES

matteuzzi srl

Via Serra, 1/E - 3

40012 CALDERARA DI RENO, ITALY

Phone ++39 - 051726351

matteuzzi@matteuzzi-srl.com - www.matteuzzi-srl.com