

10/16 M - HIGH *AUTOMATIC INSPECTION SPREADER* *for car and light truck tyres*



Macchina adatta per pneumatici vettura e trasposto leggero aventi le seguenti dimensioni:

Machine suitable for car and light truck tyres having the following sizes:

sezione min./ max.

min./ max. section

135 mm. to 300 mm.

diametro esterno min./ max.

min./max. outer diameter:

480 mm. to 800 mm.

diametro cerchio min./max.

min./max. rim dia.

13" to 24"

distanza min./max. tra i talloni

min./max. bead inner width:

70 to 250 mm.

sono disponibili diversi modelli per soddisfare qualsiasi esigenza di produzione
different models are available to satisfy all production requirements



MACCHINE PER PNEUMATICI E PER I PROCESSI DI RICOSTRUZIONE
EQUIPMENT FOR THE TYRE AND RETREADING INDUSTRIES

matteuzzi srl

Via Serra, 1/E

40012 CALDERARA DI RENO, ITALY

Phone ++39 - 051726351

matteuzzi@matteuzzi-srl.com - www.matteuzzi-srl.com

10/16 M - HIGH *AUTOMATIC INSPECTION SPREADER* for car and light truck tyres

caratteristiche principali	main features
illuminazione del pneumatico <i>tyre lighting</i>	<ul style="list-style-type: none"> ▪ due lampade per l'esterno del pneumatico <i>two lamps for the tyre external surface.</i> ▪ due lampade incorporate nei bracci divaricatori <i>two spreading arms with built-in lamps.</i> ▪ due lampade montate sui bracci divaricatori <i>two lamps fitted on the spreading arms</i>
divaricazione del pneumatico <i>tyre spreading</i>	motore da 1.0 HP con comando a pulsante e a leva <i>1.0 HP push-button and joystick controlled motor</i>
rotazione del pneumatico <i>tyre rotation</i>	motore da 0.5 HP con comando a pulsante e pedale <i>0.5 HP push-button and pedal controlled motor</i>
produzione media <i>floor to floor average output</i>	40/60 pneumatici/h - <i>tyres per hour</i>
potenza totale installata <i>total installed power</i>	1.1 kw (1.5 hp) <i>approx.</i>
alimentaz. aria compressa <i>compressed air supply</i>	6 – 8 bar se la macchina è corredata con gruppo caricatore <i>6 – 8 bar if the machine is equipped by loading system</i>
peso netto - <i>net weight</i>	300 kg.
dimens.macchina in servizio <i>dimensions of the machine in service</i>	920 x 1120 x 1250 (h) mm.



macchina completa con gruppo caricatore automatico
machine complete with automatic loading system

10/16 M - HIGH *AUTOMATIC INSPECTION SPREADER* for car and light truck tyres

dimensioni della macchina in servizio

dimensions of the machine in service

macchina standard

standard machine

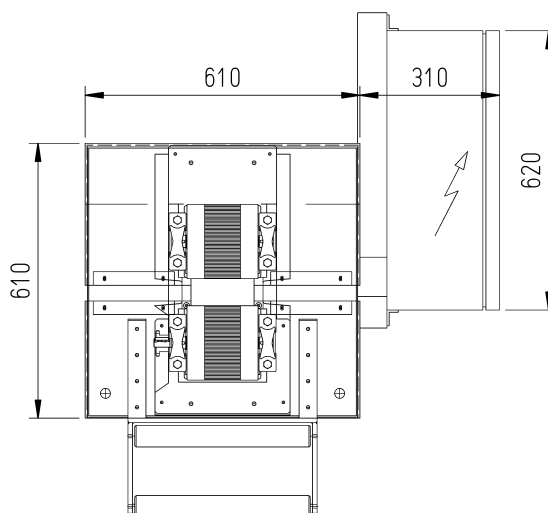
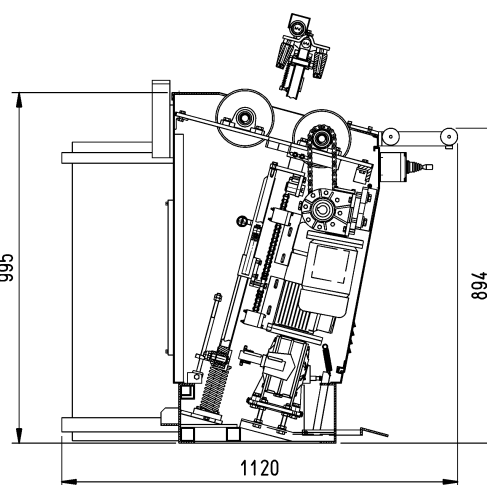
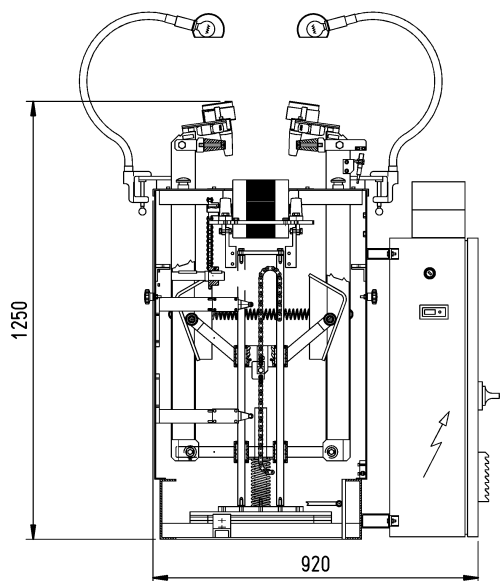

matteuzzi srl

Via Serra, 1/E
40012 CALDERARA DI RENO, ITALY
Phone ++39 - 051726351

matteuzzi@matteuzzi-srl.com - www.matteuzzi-srl.com

Due to a policy of continuous improvement, the machine may differ from the images shown