

---

# 540/P-2/PLC, AUTOMATIC SPREADING MACHINE

designed to visually check the internal and external surface of truck tyres

---



The picture shows the machine complete with HYDRAULIC TILTING TABLE



MACCHINE PER PNEUMATICI E PER I PROCESSI DI RICOSTRUZIONE  
EQUIPMENT FOR THE TYRE AND RETREADING INDUSTRIES

## matteuzzi srl

Via Serra, 1/E  
40012 CALDERARA DI RENO, ITALY  
Phone ++39 – 051726351

matteuzzi@matteuzzi-srl.com - www.matteuzzi-srl.com

# 540/P-2/PLC, AUTOMATIC SPREADING MACHINE

designed to visually check the internal and external surface of truck tyres

dimensioni della macchina in servizio  
con ribaltatore idraulico

dimensions of the machine in service  
with hydraulic tilting table

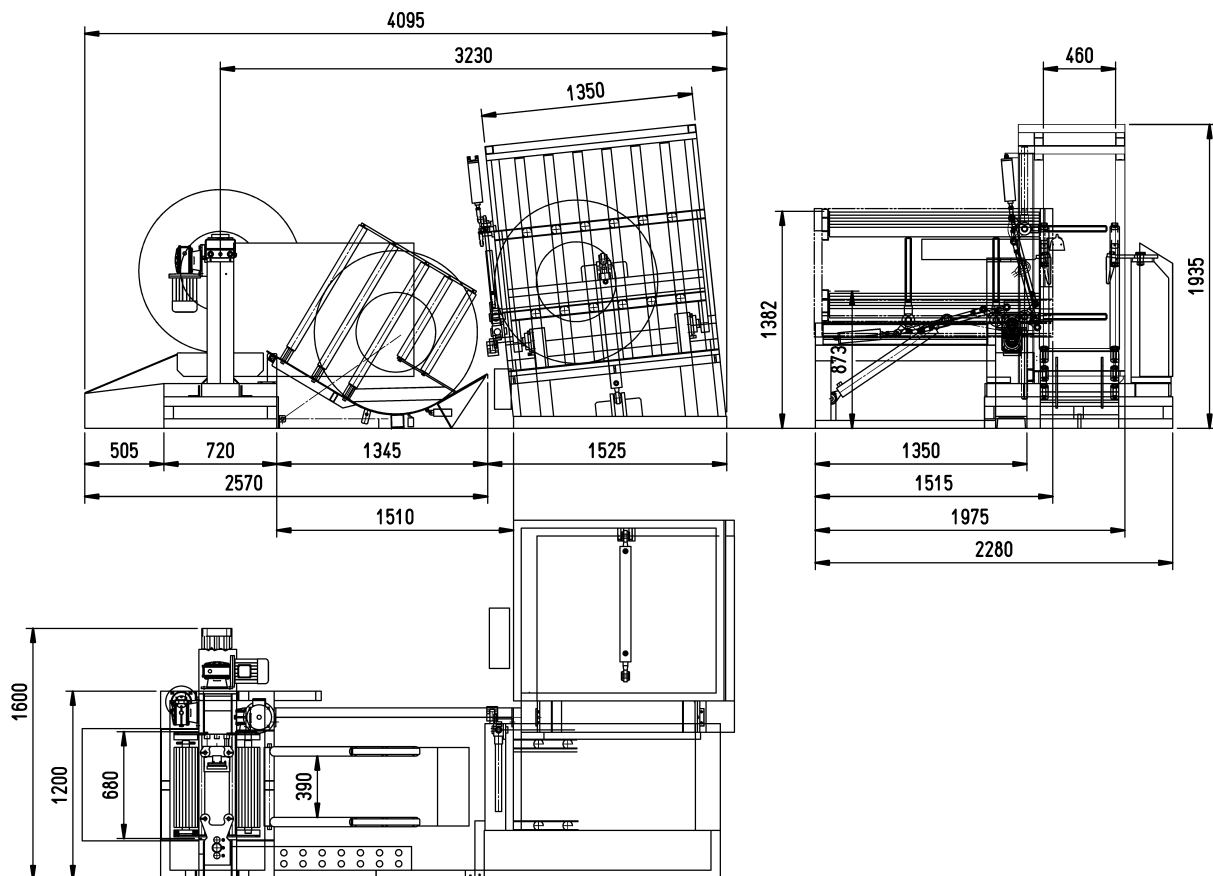

The machine performs the various operations automatically by following three working cycles, each of which corresponds to a group of tyre sizes.

macchina adatta per pneum.	<i>tyre range</i>	from 7.00-16" to 13 R 22.5" (15 R 22.5", 24" and 24.5" included)
capacità produttiva floor to floor	<i>floor to floor average output</i>	40 pneumatici /ora <i>tyre casings per hour</i>
alimentazione aria compr.	<i>compressed air supply</i>	6 ÷ 7 bar (90÷105 PSI)
assorbimento aria compr.	<i>compressed air absorption</i>	50 NI <i>per cycle</i>
potenza totale installata	<i>total installed power</i>	4 HP (3 KW). <i>approx.</i>
peso netto	<i>net weight</i>	1400 kg. <i>approx.</i>

Due to a policy of continuous improvement, the machine may differ from the images shown