

VERTICAL SPREADER FOR ENVELOPES  
***ELL Envelope Long Life system***



*raffigurata con elevatore a pavimento  
shown with floor lift*

# VERTICAL SPREADER FOR ENVELOPES

## ***ELL Envelope Long Life system***

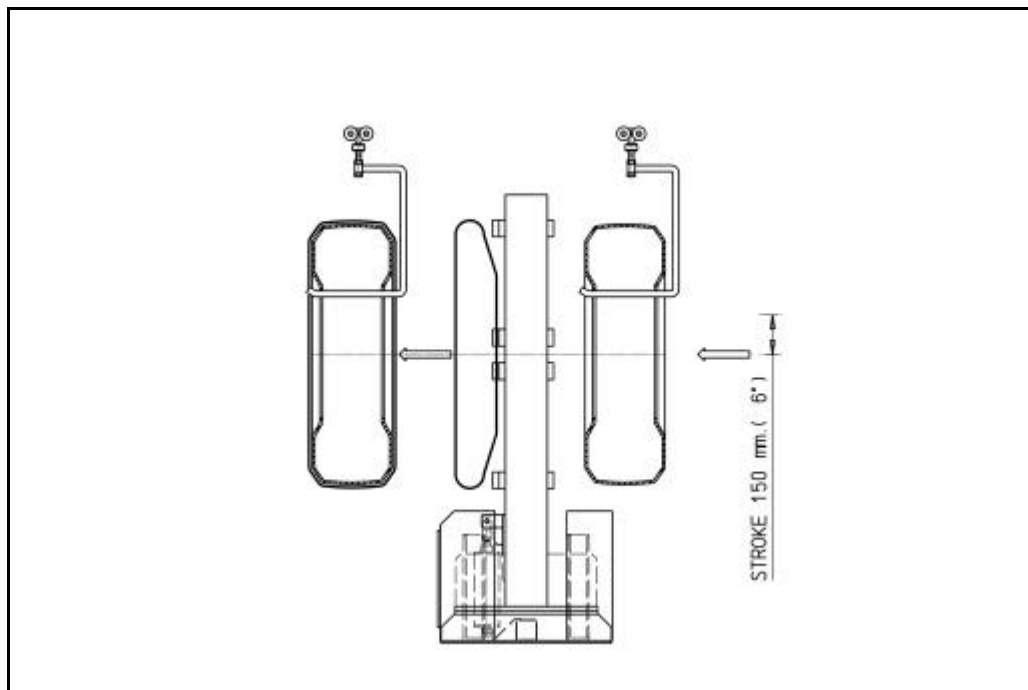

*machine with floor lift*

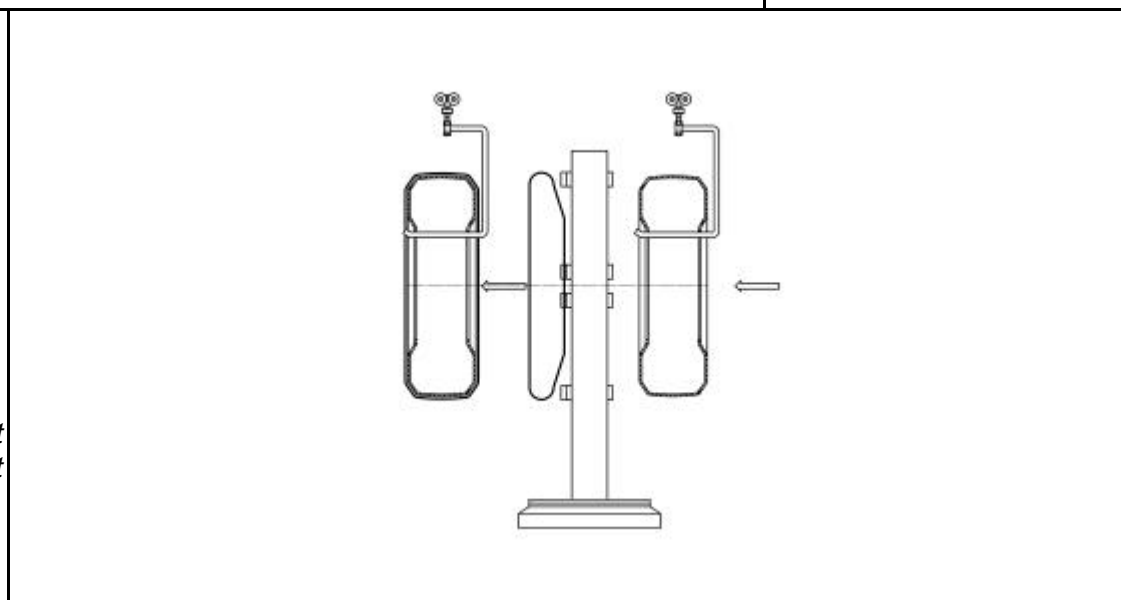

*machine without floor lift*

macchina adatta per pneum.	tyre range	16" ÷ 24.5"
alimentaz. aria compressa	compressed air supply	8 ÷ 10 bar (120÷150 PSI)
consumo aria compressa	compressed air absorption	200 NI (7.3 cu.ft.) per ciclo – per cycle
peso netto	net weight	395 kg. (888 lbs) con elevatore – with floor lift 280 kg. (630 lbs) senza elevatore – without floor lift
dimens.macchina in servizio	dimens. of the machine in service	750 x 2012 x 1707 (h) mm. (30" x 80"x 67") without floor lift